

Journal

upDate!

upDate!





**index
of
contents**



18-19	CI 233	42-43	MN 2240	68-69	MN 2545
20-21	CI 234	44-45	MN 2486	70-71	MN 2547
22-23	CI 235	46-47	MN 2492	72-73	MN 2555
24-25	CI 236	48-49	MN 2499	74-75	MN 2573
		50-51	MN 2511	76-77	MN 2576
26-27	MN 1109	52-53	MN 2523	78-79	MN 2579
28-29	MN 1133	54-55	MN 2524	80-81	MN 2582
30-31	MN 1150	56-57	MN 2529	82-83	MN 2588
32-33	MN 1179	58-59	MN 2535	84-85	MN 2590
34-35	MN 1180	60-61	MN 2538	86-87	MP 756
36-37	MN 2031	62-63	MN 2541		
38-39	MN 2048	64-65	MN 2542	88-91	PO 2092
40-41	MN 2082	66-67	MN 2543	92-93	PO 2095



Pamar ha sempre fatto di ricerca e sperimentazione un tratto caratteristico della sua storia. Altrettanto naturale è stato considerare il design Made in Italy un elemento fondamentale di distinzione e di costruzione della propria identità. Oggi, in un mondo dove, persone nonché aziende conoscono il prezzo di tutto e il valore di niente, Pamar esprime la volontà di posizionarsi in una fascia più sensibile del mercato. Rendere i suoi accessori segni inconfondibili, essenze uniche del progetto finale. Flessibili, trasversali e completamente customizzabili nella finitura.

Research and experimentation have become a distinguishing feature in Pamar's history. Subsequently, it was only natural to acknowledge Made in Italy design as the next step in the distinction and creation of its identity. Nowadays, in a reality, where people as well as industries know the price of everything and the value of nothing, Pamar hardly signaled its interest in positioning itself in the most sensitive, higher end market. Producing not just accessories, but distinctive signs, unique essences of the final project. Details with their own personality, an undeniable style, completely customizable in finishes, that could not go unnoticed.

"In order to be irreplaceable,
one must always be different"

-C.Chanel-

SHAPES

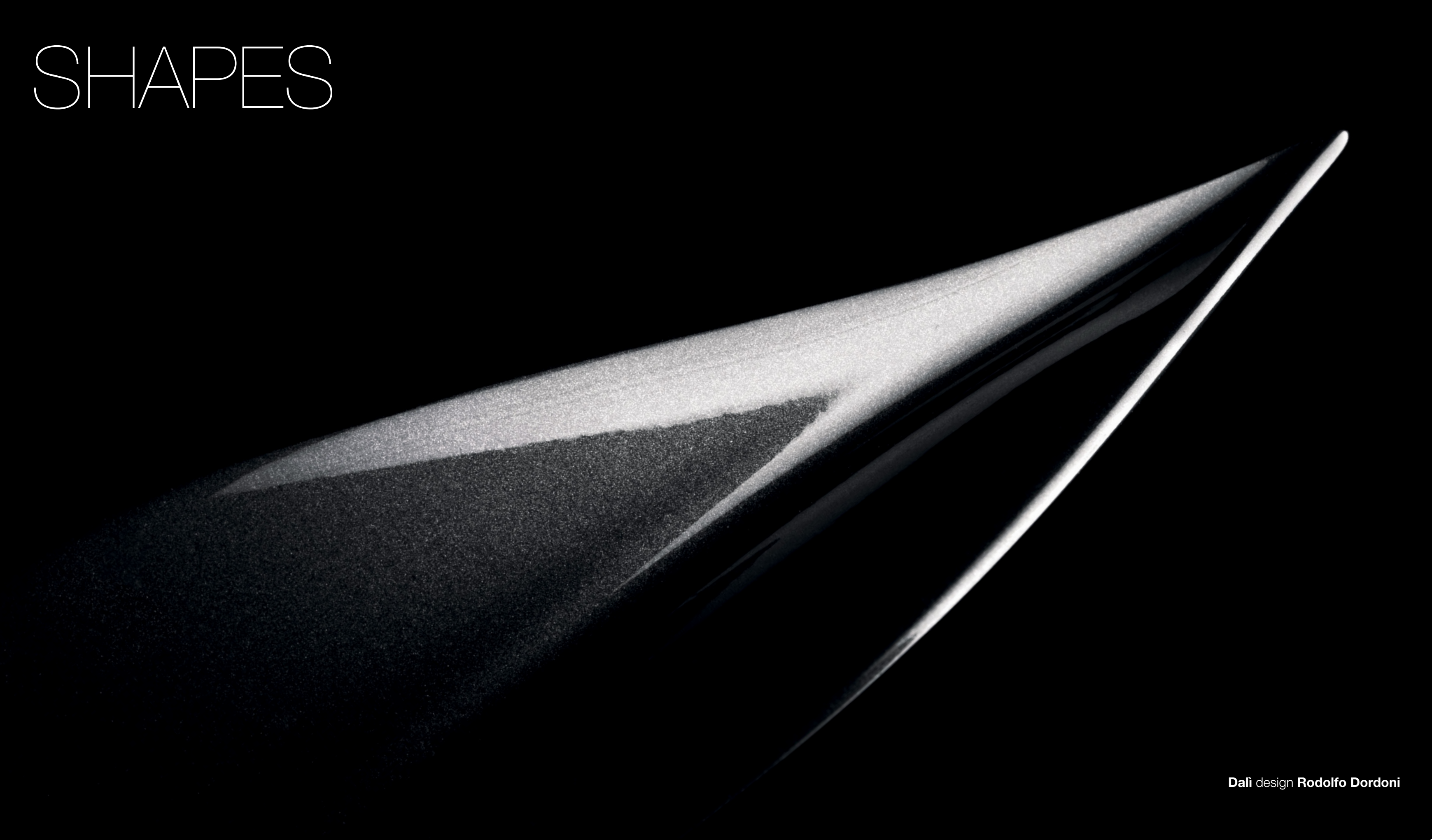

Godronè design Marco Redaelli





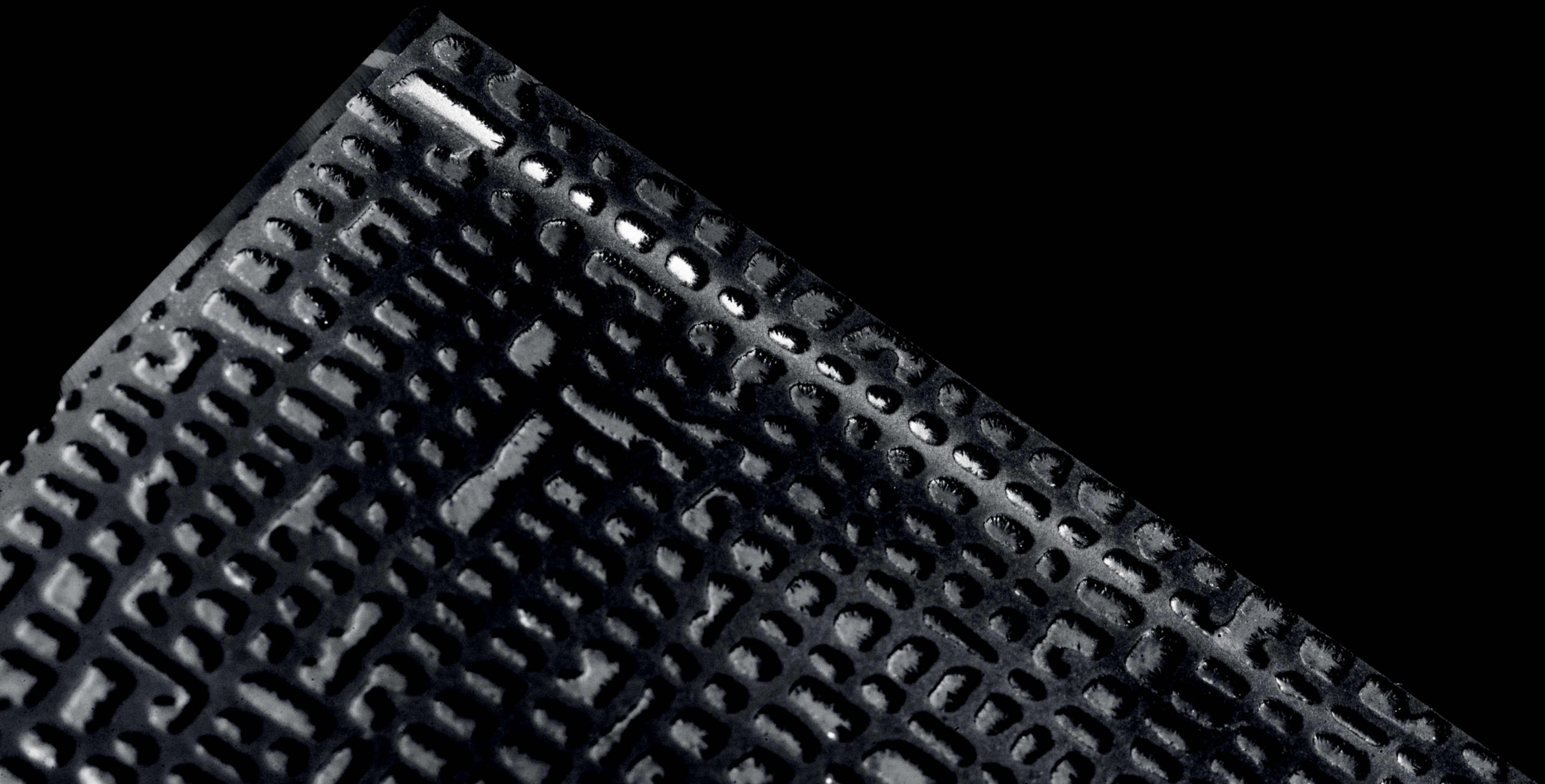





CI 233 Z
design Giuseppe Bavuso





CI 234 Z
design **Giuseppe Bavuso**



CI 235 Z
design **Giuseppe Bavuso**





CI 236 Z
design **Giuseppe Bavuso**





MN 1109 Z
design **Rodolfo Dordoni**





MN 1133 I
design **Giuseppe Bavuso**





MN 1150 Z
design **Marco Redaelli**





MN 1179 Z
design **James Irvine**





MN 1180 Z
design **James Irvine**





MN 2031 Z
design Giuseppe Bavuso



MN 2048 Z
design **Pinuccio Borgonovo**



MN 2082 Z
design **Pinuccio Borgonovo**





MN 2240 Z
design **Pinuccio Borgonovo**



MN 2486 Z
design **Michele Marcon**





MN 2492 Z
design Michele Marcon



MN 2499 Z
design **Giuseppe Bavuso**

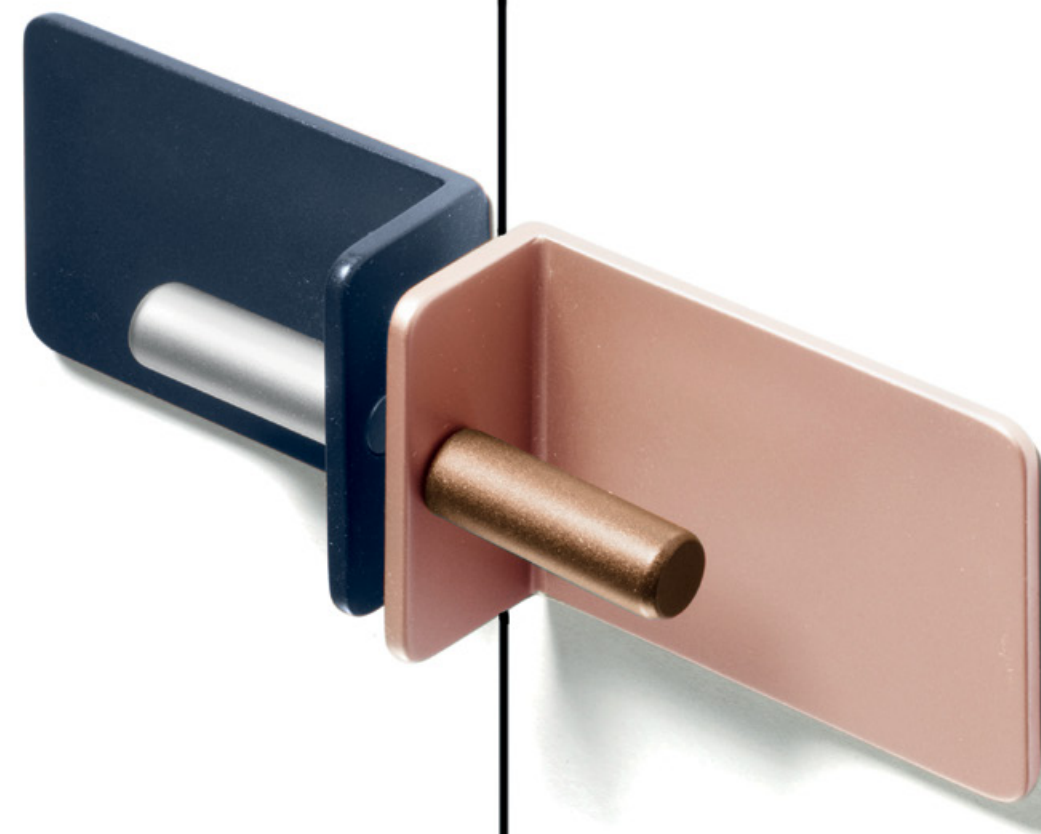



MN 2511 Z
design **Marco Redaelli**

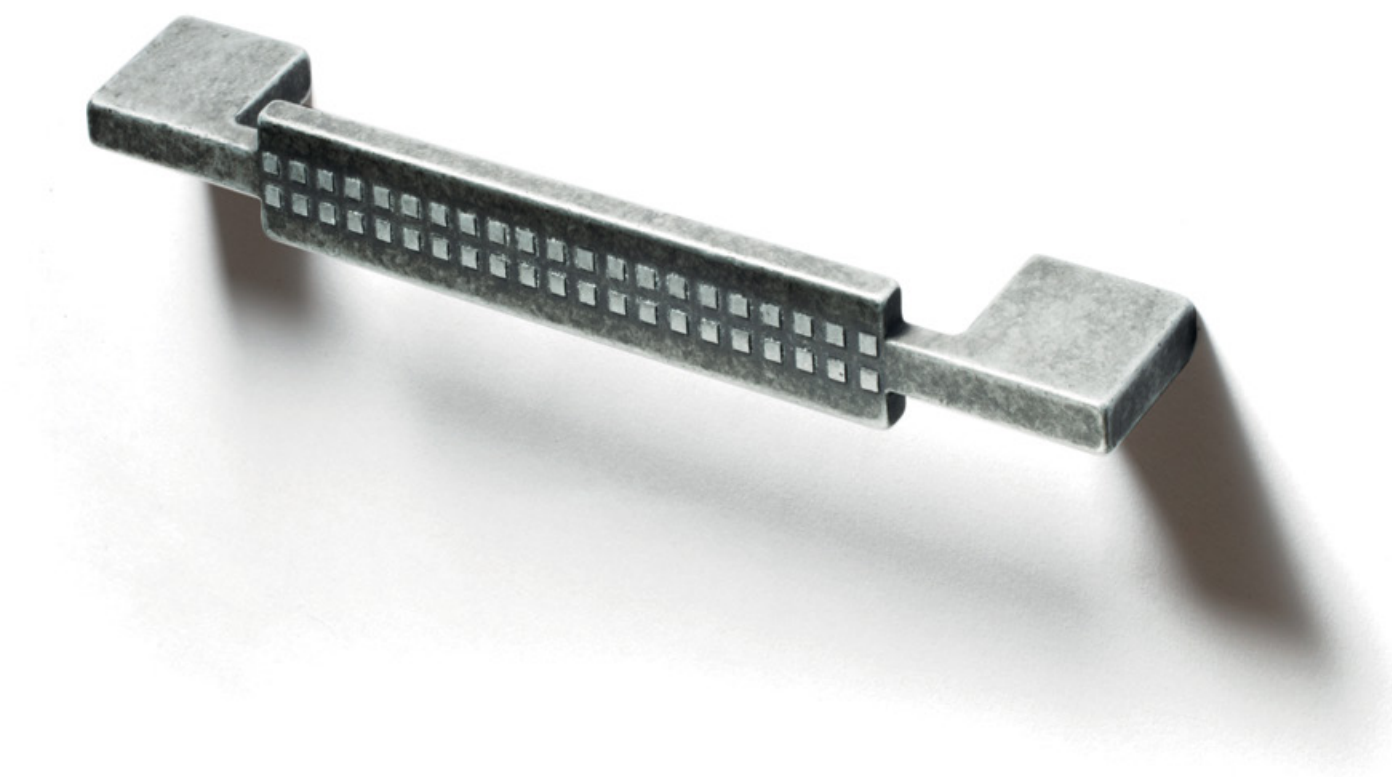

MN 2523 Z
design **Michele Marcon**





MN 2524 Z
design **Michele Marcon**





MN 2529 Z
design **Michele Marcon**





MN 2535 Z
design **Giuseppe Bavuso**





MN 2538 Z
design **Marco Redaelli**





MN 2541 Z
design **Marco Redaelli**





MN 2542 V
design **Marco Redaelli**





MN 2543 V
design **Marco Redaelli**

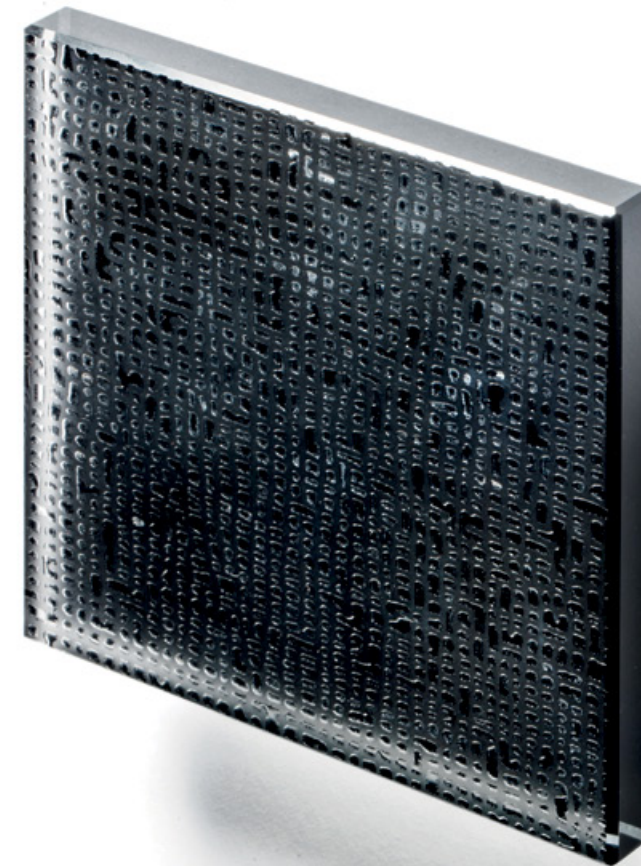



MN 2545 Z
design **Marco Redaelli**



MN 2547 Z
design **Marco Redaelli**



MN 2555 Z
design Michele Marcon





MN 2573 Z
design **Michele Marcon**





MN 2576 Z
design **Michele Marcon**



MN 2579 Z
design **Marco Redaelli**



MN 2582 Z
design **Gioipaw**





MN 2588 Z
design **Simone Micheli**





MN 2590 Z
design **Marco Redaelli**





MP 756 Z
design **Marco Redaelli**





PO 2092 L
design Jasper Morrison

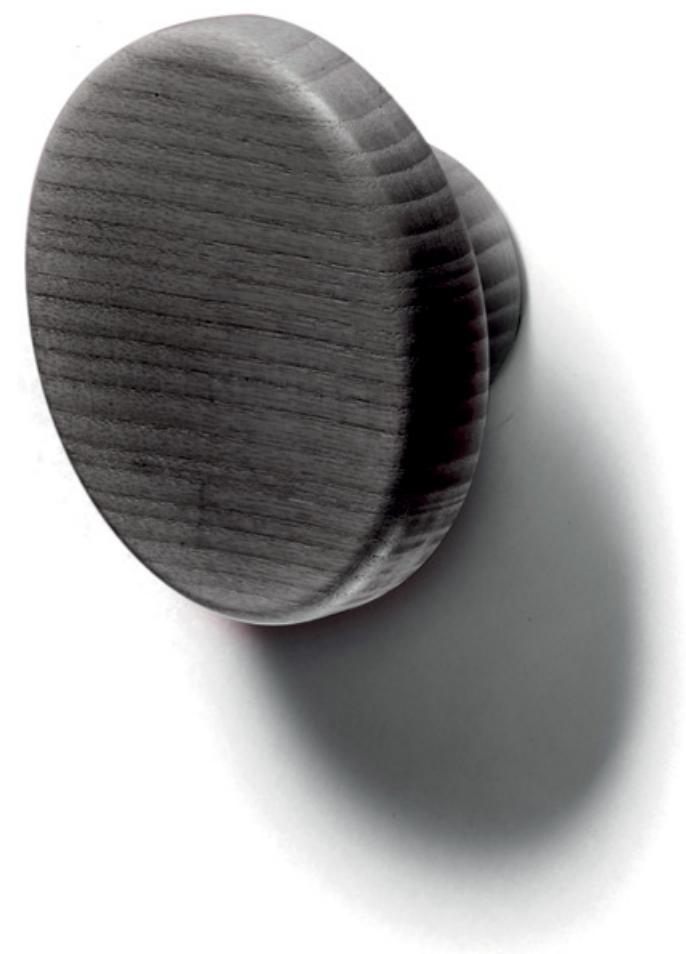



PO 2092 L
design Jasper Morrison



PO 2095 Z
design Gioipaw



Technical drawings

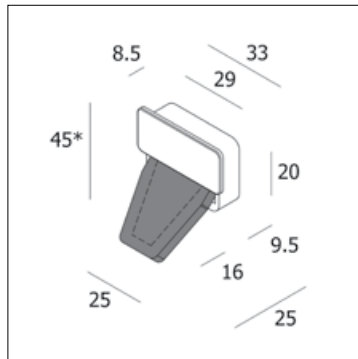

CI 233 Z

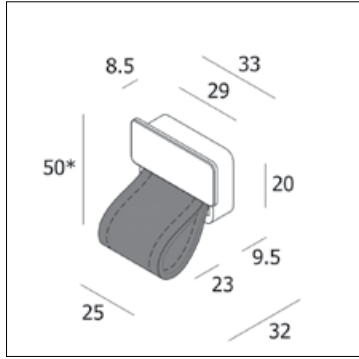

CI 234 Z

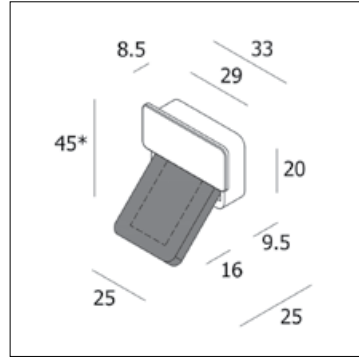

CI 235 Z

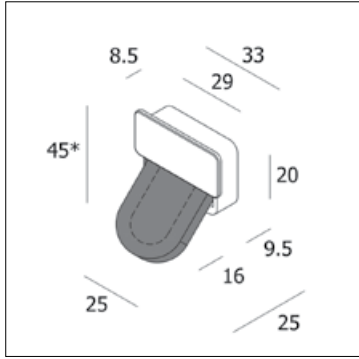

CI 236 Z

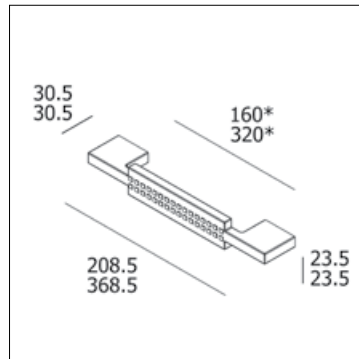

MN 2511 Z

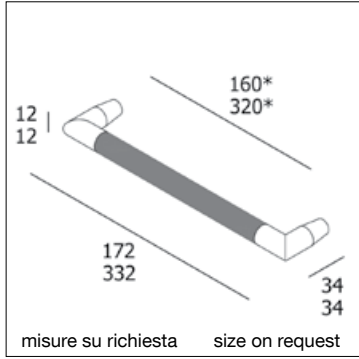

MN 2523 Z

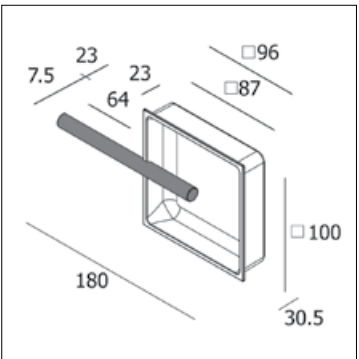

MN 2524 Z

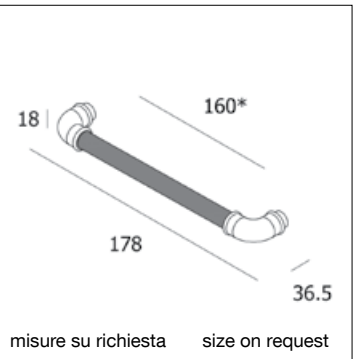

MN 2529 Z

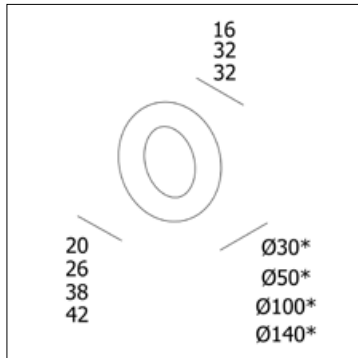

MN 1109 Z

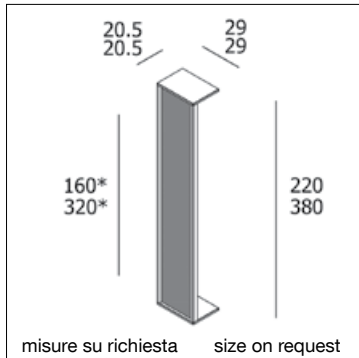

MN 1133 Z

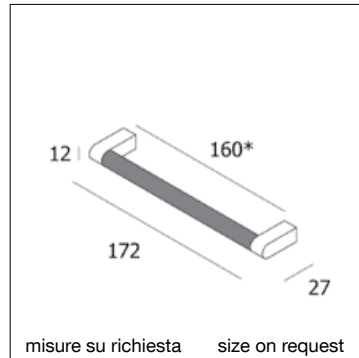

MN 1150 Z

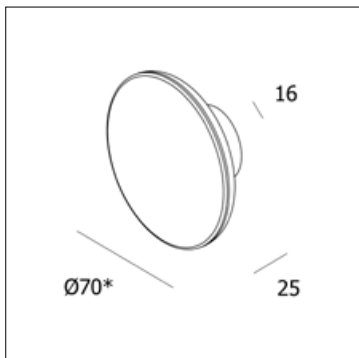

MN 1179 Z

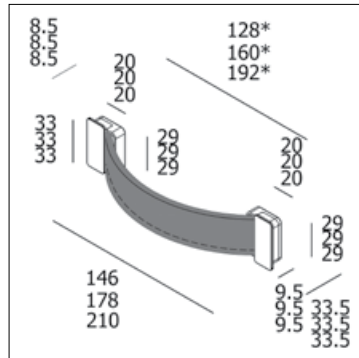

MN 2535 Z

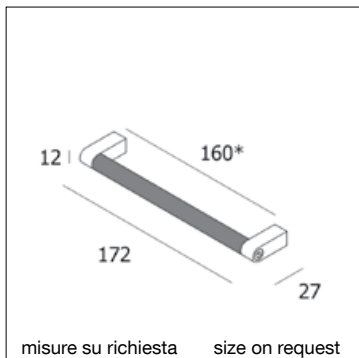

MN 2538 Z

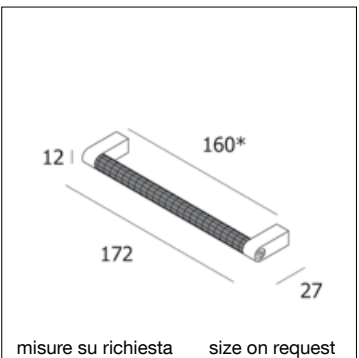

MN 2541 Z

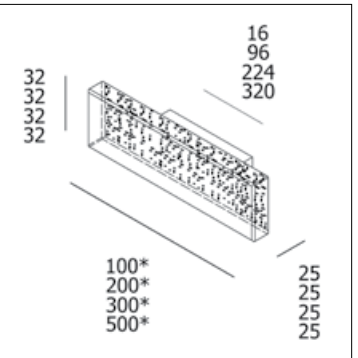

MN 2542 V

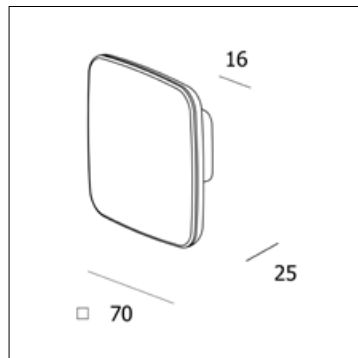

MN 1180 Z

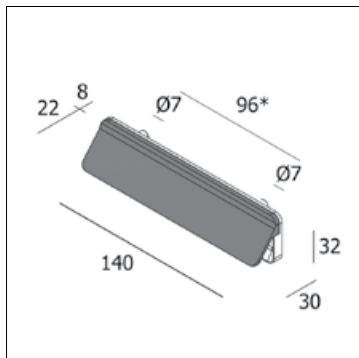

MN 2031 Z

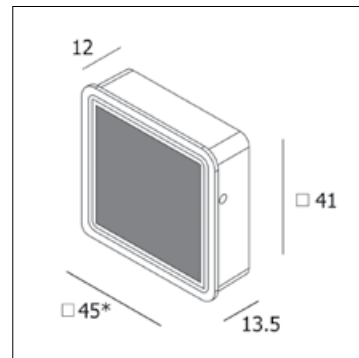

MN 2048 Z

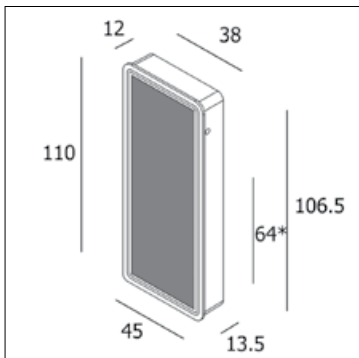

MN 2082 Z

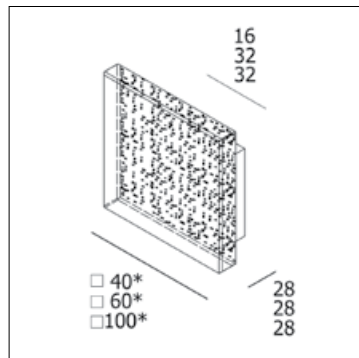

MN 2543 V

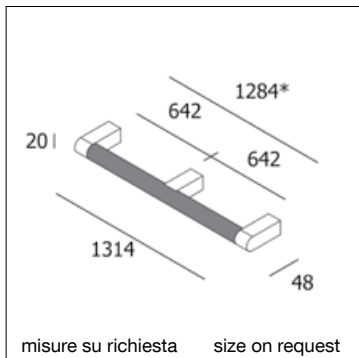

MN 2545 Z

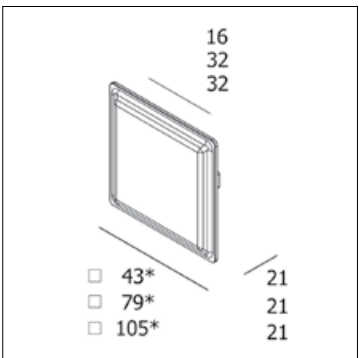

MN 2547 Z

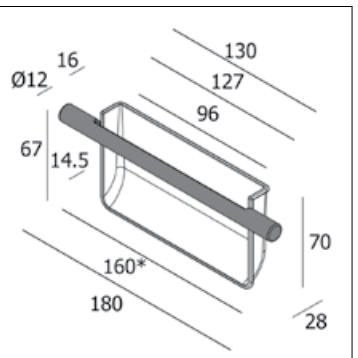

MN 2555 Z

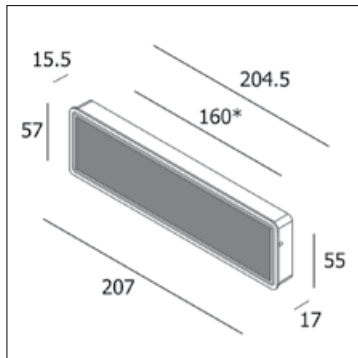

MN 2240 Z

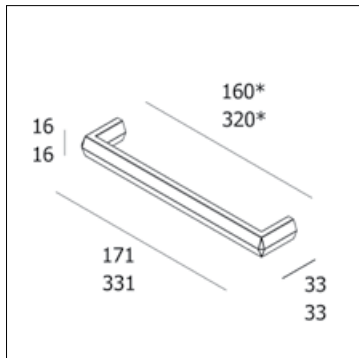

MN 2486 Z

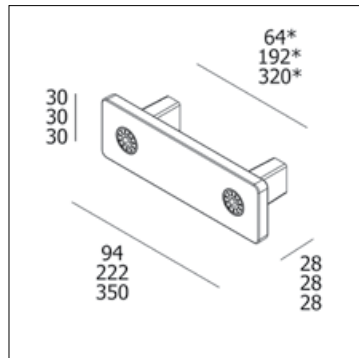

MN 2492 Z

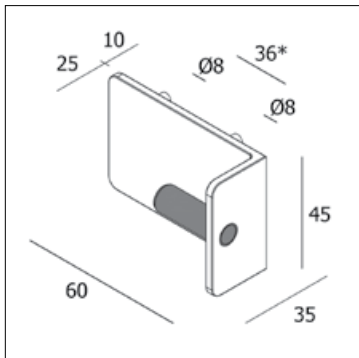

MN 2499 Z

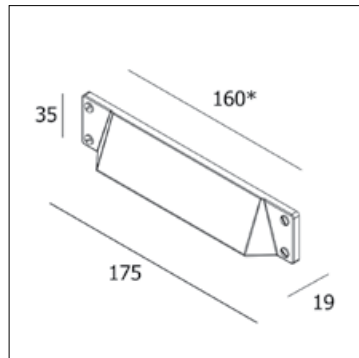

MN 2573 Z

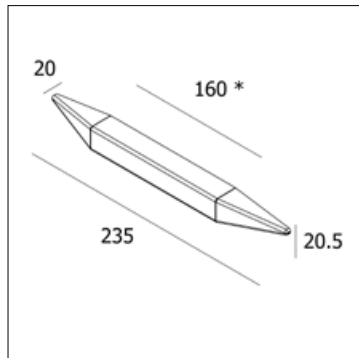

MN 2576 Z

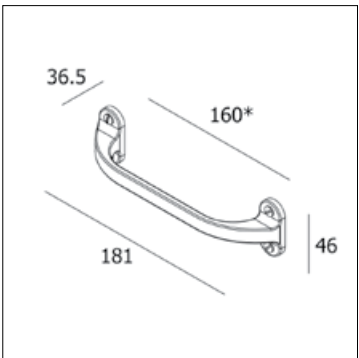

MN 2579 Z

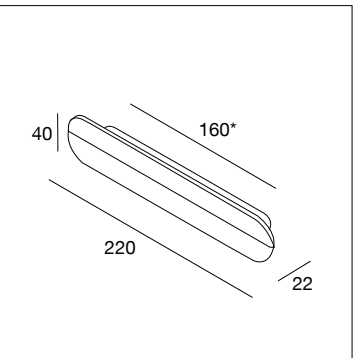

MN 2582 Z

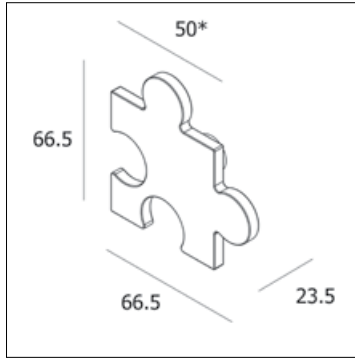

MN 2588 Z

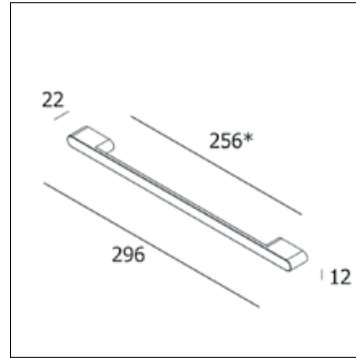

MN 2590 Z

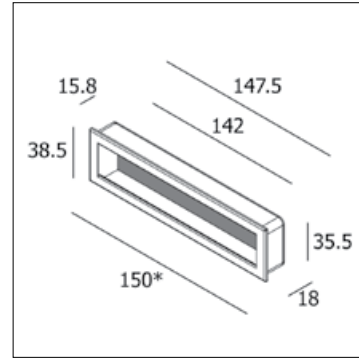

MP 756 Z

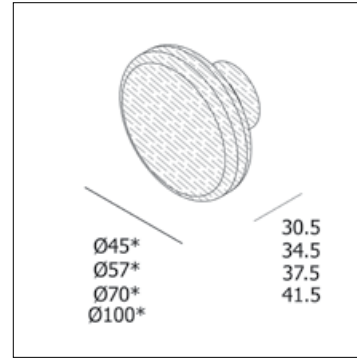

PO 2092 L

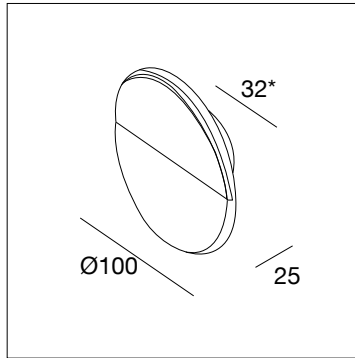

PO 2095 Z

PRIVACY

I modelli Pamar sono protetti da brevetto internazionale. La contraffazione sarà perseguita a termini di legge.

International patents have been deposited for the Pamar models. Imitations will be punished by law.

Die Modelle Pamar sind durch internationales Patent geschützt. Fälschungen sind strafbar und werden gesetzmäßig verfolgt.

Les modèles Pamar sont couverts par un brevet international. La contrefaçon sera poursuivie aux termes de la loi.

Los modelos Pamar están protegidos por patente internacional. La imitación será demandada según las leyes.

INFORMAZIONI TECNICHE

- Le misure in nero sono le dimensioni esterne
- Le parti in grigio scuro nei disegni indicano applicazioni di differenti finiture
- Le misure con asterisco sono il codice del prodotto

AVVERTENZA

Pamar Srl si riserva la facoltà di modificare le caratteristiche tecniche degli elementi illustrati nel presente catalogo in qualunque momento che si ritiene necessario. Descrizioni, foto, colori e misure indicate per i prodotti presenti in catalogo sono solamente indicativi.

TECHNICAL INFORMATION

- Black measurements refer to external dimensions
- The dark grey shadings in the drawings indicate applications of different finishes
- Measurements with asterisk refer to the article code

ATTENTION

Pamar Srl reserves the right to change technical specifications of products illustrated in this catalogue at any time it deems necessary. Descriptions, photos, finishes and product sizes showed in the catalogue are not binding.



AD, photo and graphics

Andrea Basile Studio

copy, translations and supervisor

Elena Redaelli

many thanks to

**Federico Corchia
Sara Dassi
Silvio Dell'Oro
Naomi Fagnoni
Davide Gelosa
Elisa Mauri
Alice Riva
Vic + Areti**

shoot at

Gelosa3 Galleria Creativa

proudly powered by

Pamar S.r.l.
via Sirtori 41 20838 Renate (MB)
t +39 0362 924661/2/3 f +39 0362 924612
pamar@pamar.it www.pamar.it

